

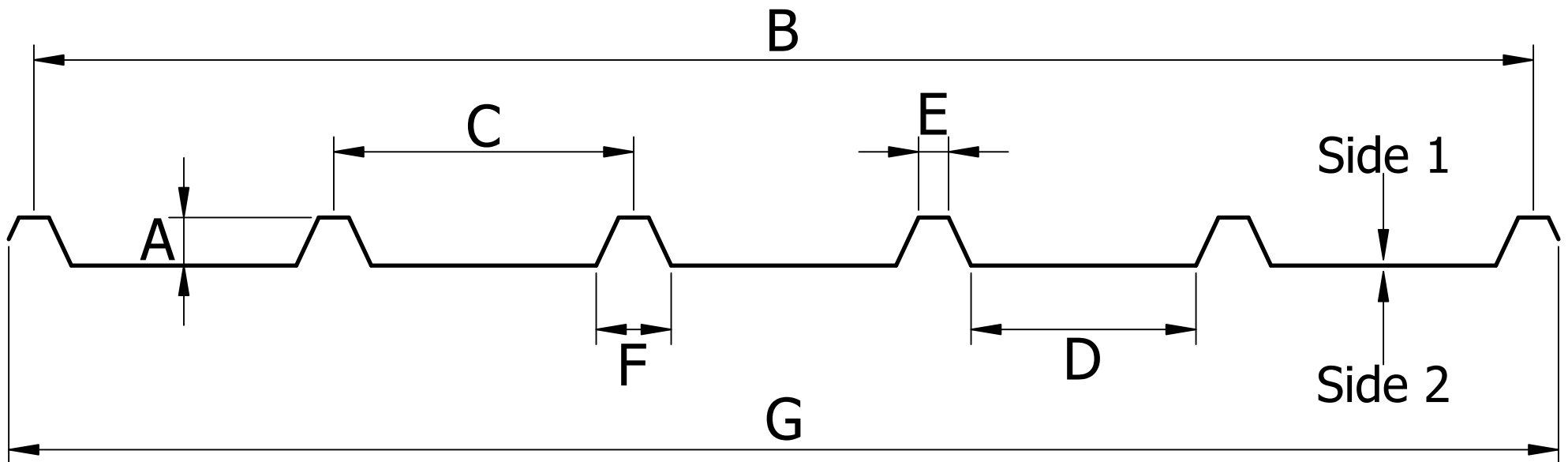

Please fill in the form below and return to our sales team by email, fax or post

Profile Dimensions



A	B	C	D	E	F	G	Colour Side
Profile Height	Cover Width	Pitch	Pan	Crown	Under Crown	Overall Width	

Steel Sheets

Material	
Galvanised Steel (Self Colour)	
Polyester Painted Steel	
Plastisol Coated Steel	
Colour	
No. Sheets	Length (m)

GRP Rooflights

Fire Rating Class	Weight (kg/m ²)			
	2.4	3.0	3.6	4.2
3				
1				
0				
No. Sheets	Length (m)			

Foam Fillers

Pairs (Fill Gaps Side 1 & 2)	
Large Flute (Fill Gaps Side 1)	
Small Flute (Fill Gaps Side 2)	

Each foam filler will match the width of 1 sheet

Due to the tolerances involved with manufacture and the difficulty in getting accurate measurements from the sheet we always recommend you send a sample to ensure the measurements are accurate and the sheets will fit together as closely as possible. We can manufacture from drawings if necessary but providing a sample will give the most accurate results. If a sample cannot be provided we will first try our best to identify your profile and match to an existing cladding specification. We will send you the nearest drawings we can find for you to approve.